

BENEFITS OF CONTROLLED TRAFFIC FARMING

Jiří Mašek, Milan Kroulík, František Kumbála

Faculty of Engineering Czech University of Life Sciences Prague

Kamycka 129, 165 21 Prague, Czech Republic

masekj@tf.czu.cz

Abstract. The GPS guidance systems are used almost in all field operations. In relation to the soil protection against erosion and compaction, possibilities to use other guidance systems are also looked for at present time. Of heavy agricultural machinery across the field are a common practice nowadays; however they leave mainly random trails. As a result of this fact, soil is very often subject to repeated pass and therefore to irreversible structural changes of soil because of its compaction. According to literature sources and many experiments, soil compaction caused by repeated passages of agricultural machines across the field reduces its infiltrability, hydraulic conductivity, porosity, aeration and increases its bulk density and resistance to root development. The guidance systems and the Controlled Traffic Farming system, which are based on maintaining the same wheel track in a period of several years for each operation on the field, is one of the tools which can be used for soil protection against soil compaction.

Keywords: controlled traffic farming, GPS, soil compaction.

Introduction

Controlled traffic farming (CTF) is a guiding system the aim of which is to control soil compaction – confining it to narrow strips across the land and maximizing the remaining undamaged soil area for cropping. In practice it means that the tracks of machinery are adjusted in such a manner that they take up the least possible area. Although, this can be done in a simpler way - by means of satellite guidance, it can be achieved also using the conventional marking systems. The conversion of farming to CTF primarily means adopting a CTF "mindset" – the belief that separation of the trails made by the wheels from the strips of land under crops is the key method how to reduce the costs and increase the returns. Consequently, it is simply a matter of good planning and timely investments that ensures a minimum 15 % return on capital, an increase in crop returns, and a substantial reduction in costs [1].

Controlled traffic farming cuts the fuel, labour and machinery costs dramatically reducing soil damage. This makes farming simpler, more reliable and less time consuming. It also gives environmental benefits, such as reduced water run-off and soil erosion, more efficient application of fertilizers, less risk of nitrous oxide and methane emissions, and improved carbon sequestration. On the whole, with reduced fuel, energy and machinery inputs and fewer greenhouse gas emissions, the carbon footprint of CTF is likely to be the lowest compared to all the other farming systems.

CTF is a simple way how to reduce dramatically the input costs (time, fuel & machinery) – increasing at the same time the crop yields - both of which are sustainable and both of which increase the profit of the farm. CTF is a whole-farm approach to the separation of the strips of land under crops from the trails made by the wheels; it is a system that averts extensive soil damage and reduces the costs when the conventional methods are used. Controlled traffic is not a rocket science – it simply implies accumulation of all the field vehicles on the least possible area of regular traffic.

Appropriate agronomy and management is used to maximize the potential of both the cropped and wheeled areas for their specific purposes. In practice it means repeated use of the same wheel tracks for every operation. Although it is ideal for all machines to have the same wheel track (the distance between the left and right wheel centres) and for all implements to have a particular span (base module), or its whole number multiple, this is not essential. The percentage of the area wheeled can be reduced to 30-40% even with two different tracks and widths of the implements. The figure below illustrates an optimized CTF set-up with a planter, a harvester and a chemical applicator [1].

CTF is appropriate for anyone who is growing crops on any scale, irrespective of whether this is grass, roots, energetic crops, legumes or cereals, and whether they are grown applying manual, semi- or highly-mechanized systems. It is a system that cuts the costs; it creates opportunities and avoids compromises associated with soil compaction under the wheels, rutting and poor cloddy seedbeds [2]. It should be the goal of all producers. CTF can be used in the conventional soil tillage system based on

ploughing, but ploughing deprives of some benefits in the hope that it will not be necessary. It is clear that ploughing loosens all the trails left by the wheels and in many cases displaces the compacted soil laterally. To minimise the damage caused by ploughing, the tractor hauling the plough should work on the land, not in the furrow, and the direction of ploughing should be at a right angle to the trail of the wheels.

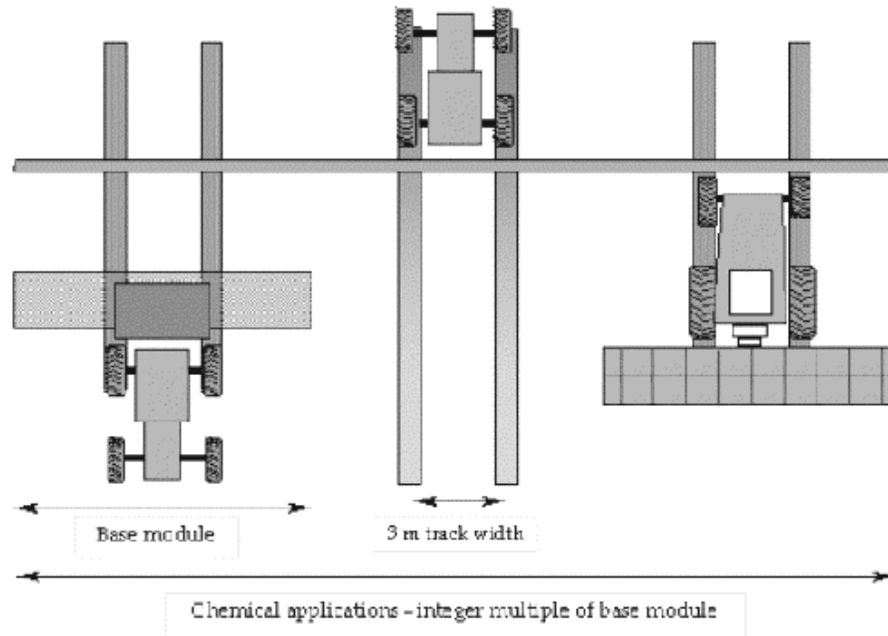

Fig. 1. CTF system with a base module of 9 m and a 3 times multiple to give 27 m for chemical applications. The width of the wheel track is 3 m [1]

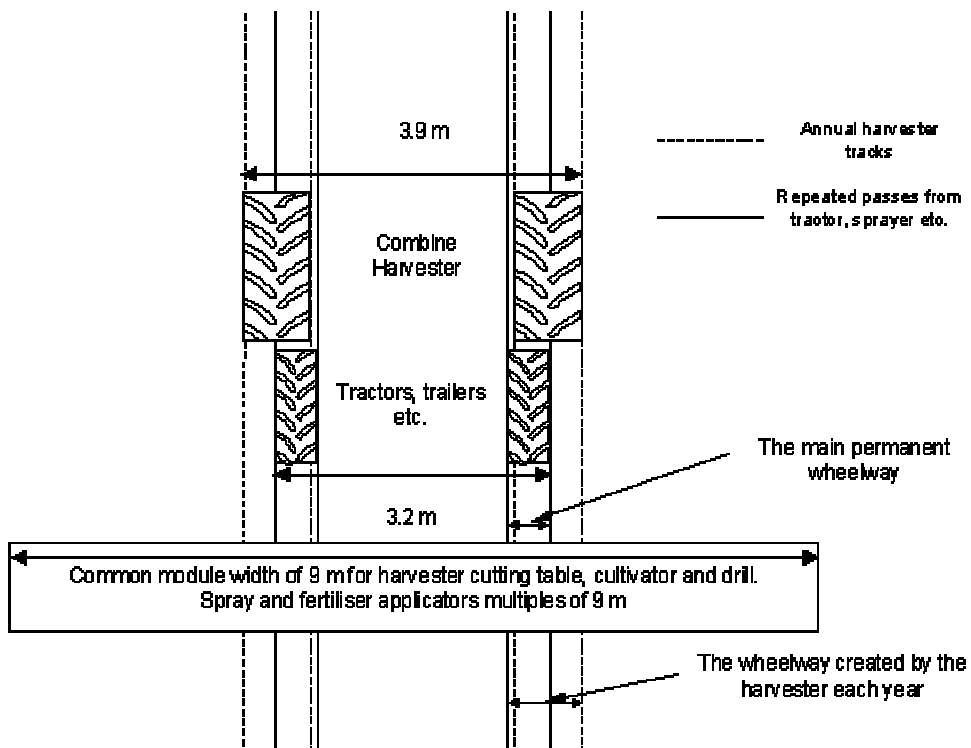

Fig. 2. The common module of different types of tractor, sprayer, trailer and harvester [1]

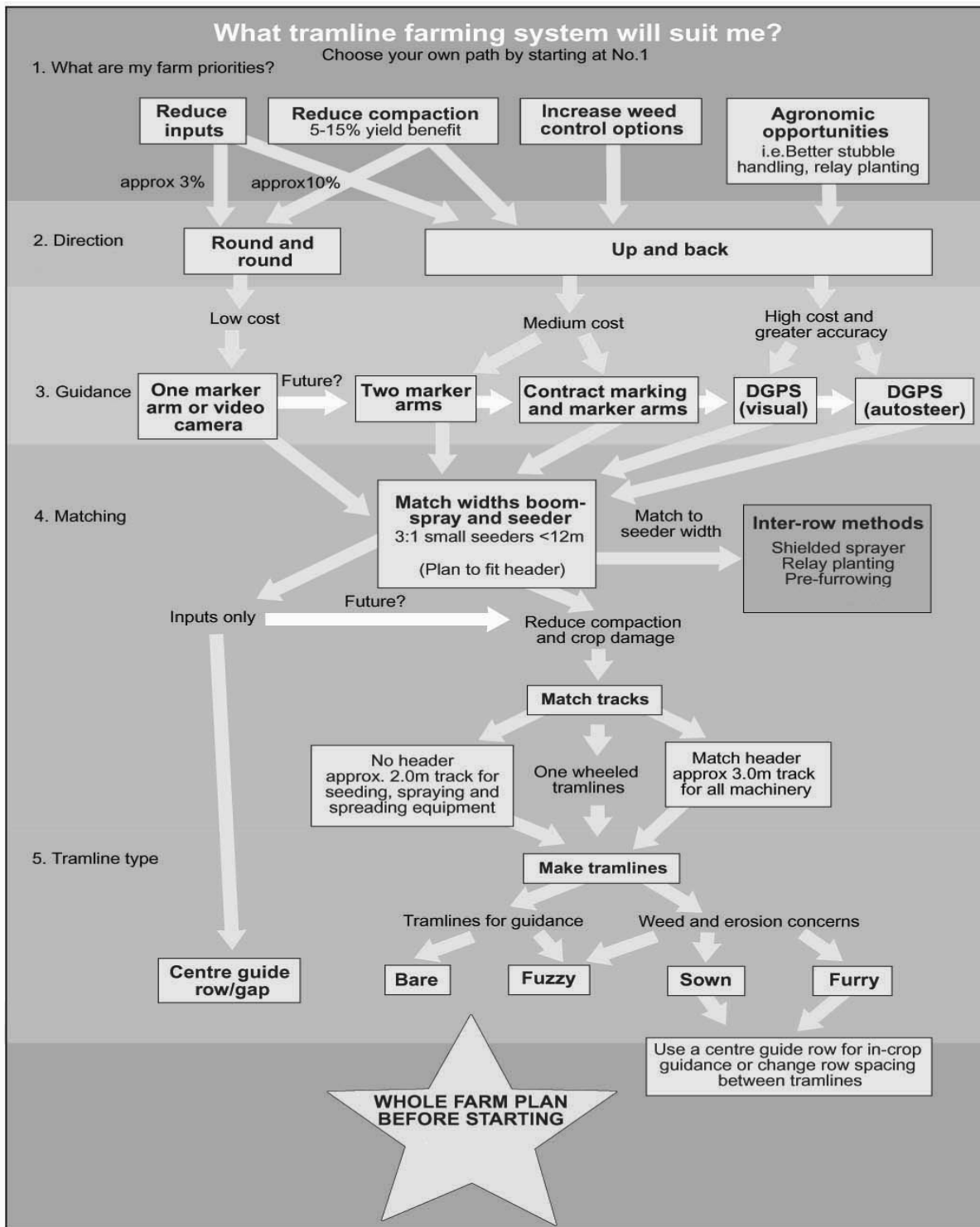

Fig. 3. Decision tree of CTF [4]

As with most benefits, there is some price to pay, and with CTF this is largely associated with the need for an improved and more sophisticated level of management. In addition, some modification of machines might be necessary. This generally means altering the gauge of the wheel, for example, by adding markers, or perhaps extending the unloading augers on the grain harvesters. Proper long-term planning will ensure that these relatively small costs are kept to a minimum, and that the machinery replacement is in line with the new needs of the farming system.

There are many benefits associated with CTF and they all help to ensure the two most important factors of the farming operations - increased profit and improved sustainability [3]. They are achieved

by improving soil health, which, in its turn, lowers the costs and increases the yields. They also ensure improved environmental conditions. Lower costs and increased returns are brought about by [1]:

- Lower energy for cultivation.
- Lower energy for driving over the soil.
- Lower machinery investment.
- Better seedbeds.
- Improved soil structure.
- Increased potential and accuracy for global positioning systems.
- Improved fertilizer use efficiency.
- Potential to retain more organic matter and soil living organisms.
- Improved water storage.

Materials and methods

In order to obtain the input data for further research in Controlled Traffic Farming systems, several measurements of the frequency and total area of machinery passes in a field were done. The experiment was prepared under real field condition by using the conventional soil tillage system. The field under study is situated in the western part of Central Bohemia. Observations were carried out for all the operations during the year, starting from soil preparation until soil tillage after the harvest. In order to conduct experiments, we needed only a DGPS receiver and a data storage unit. The DGPS receiver was installed onto a machine for monitoring all passes of the machine across the observed fields with a 2s logging time for saving the data about their position on the field. The total area covered by the tyres of the machine was calculated according to the width of its tyres and the number of the machines.

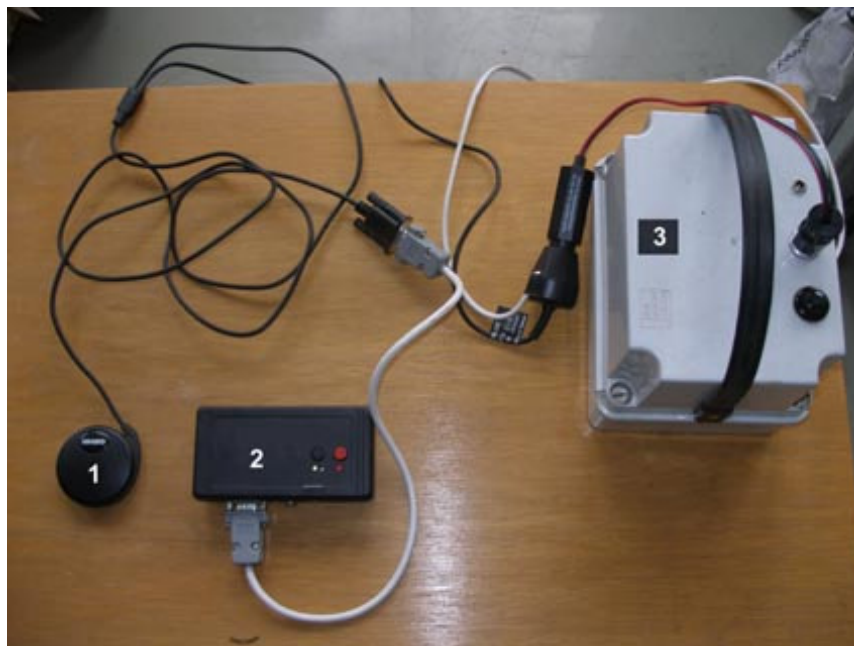

Fig. 4. The equipment for data collection: 1 – GPS receiver; 2 – data storage unit; 3 – battery

Results and discussion

The observations of all the operations were conducted all year round. The conventional soil tillage system was used on the field with ploughing as the main soil tillage operation. Figure 5 shows the trails of various machines on the surface of the field in a 1 ha segment. For better visibility we used a trajectory of individual passes only. The total area covered by all the tyres of the machine was calculated with help of the ArcGIS 9 software. The results show a considerably high number of contacts of the tyres with the soil. The total area covered by the passes of the tyres and which is calculated for the conventional soil tillage is, on the average, 96 % of the total area of the field.

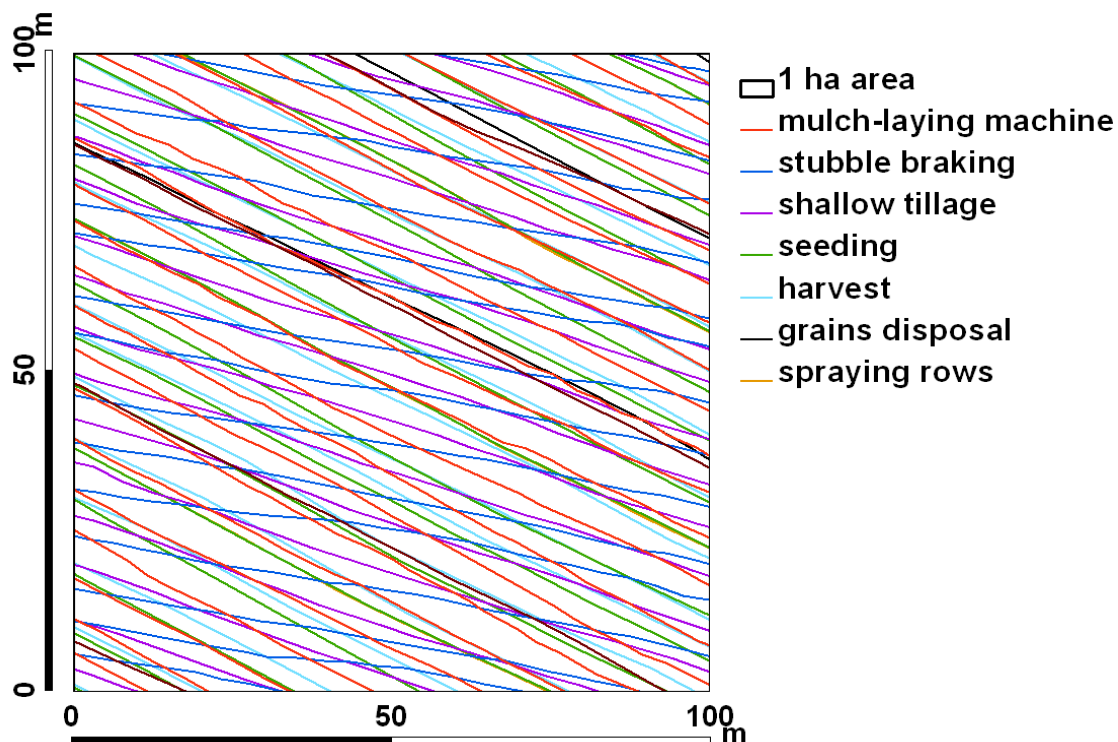

Fig. 5. The trajectories of the operation tramlines on a 1 ha segment of the field

We model for this field using different soil tillage systems. Very interesting results were obtained using minimum soil tillage technologies. If conservation soil tillage technologies are applied, the total area covered by the tyres will be only 65.5 %, but if a no-till technology is used, this area is only 42.2 %. These figures show the greatest benefit of controlled traffic farming. By using the conservation soil tillage technologies and a system of permanent tramlines is possible to achieve that a smaller area is compacted by the tyres and the soil structure is less destructed. Total area covered by the passes is less than 30 %.

Conclusion

In order to obtain the input data for further research of the controlled traffic farming systems, several measurements of the frequency and the total area covered by the passes of machine in a field were made. DGPS receivers were installed onto a machine for monitoring all passes of the machinery across the observed fields with a 2 s logging time saving the data about their position on the field. The total area covered/run-over by all the tyres of the machine was calculated with help of the ArcGIS 9 software. The results show a considerably high number of contacts of the tyres with the soil when the conventional soil tillage system and random traffic farming are used.

References

1. Chamen, T., Alakukku, L., Pires, S., Sommer, C., Spoor, G., Tijink, F., Weisskopf, P. 2003. Prevention strategies for field traffic-induced subsoil compaction: a review Part 2. Equipment and field practices. *Soil tillage research*. 73. p. 161 – 174.
2. Radford, B.J., Yule, D.F., McGarry, D., Playford, C. 2007. Amelioration of soil compaction can take 5 years on Vertisol no till in the semi-arid subtropics. *Soil tillage research*. 97 (2), p. 249-255.
3. Tulleberg, J.N. 2000. Wheel traffic effect on tillage draught. *Journal of agricultural engineering research*. 75 (4), p. 375-382.
4. Webb, B., Blackwell, P., Reithmuller, G., Lemon, J. 2004. Tramline farming system – technical manual. Bulletin 4607, Department of Agriculture Western Australia, 88 p.

This paper has been supported by Ministry of Agriculture as project No. QH 92105.