

EXPERIMENTAL RESEARCHES ON INFLUENCE OF FUNCTIONAL PARAMETERS OF GRAVITY SEPARATOR ON QUALITY INDICATORS OF SEPARATION PROCESS WITH APPLICATION ON CLEANING OF WHEAT SEEDS

Carmen Bracacescu¹, Ion Pirna¹, Cristian Sorica¹, Simion Popescu², Octavian Stan²

¹National Institute of Research-Development for Machines and Installations designed to Agriculture and Food Industry – INMA, Bucharest, Romania; ²Transylvania University of Braşov, Romania
carmenbraca@yahoo.com

Abstract. The paper presents experimental research of qualitative indexes of impurities separation out of grain seeds for equipment using combined principles of separation (according to specific mass and aerodynamic properties of seeds). The experimental installation used was composed of a gravity separator with a mechanical shaker with unbalanced masses (mounted on the platform working surface) and an aspiration installation with a fan. The experimental research has aimed at quantitative and qualitative influence on separation quality index of the following operating parameters: material flow rate of the shaking separator, air flow of aspiration installation, tilting work surface, work surface oscillation amplitude. Based on the data obtained by the measurements and qualitative indicators the separating process indexes have been determined, namely: degree of impurities separation, degree of good seed loss, as well as the index of technological effect for different types of combinations of separation installation parameters.

Keywords: cleaning, specific mass, aerodynamic separation.

Introduction

Before being milled, grains are subjected to cleaning operations aiming mainly at the elimination of foreign bodies from the mass of seeds. The main properties that underlie the separation of impurities are: difference in shape and size, difference in specific mass (density), aerodynamic properties and magnetic properties.

To reduce the number of technical equipment and implicitly of technological spaces, the modern milling units performing use complex installations carrying out the separation by combined principles, the most used following the specific mass difference being the ones and aerodynamic properties of various components of seed mixtures. The most technical equipment used of this type are the aspiring vibrating separators.

The working process diagram of combined equipment using two principles of separation (difference in specific mass and aerodynamic properties) for impurities in the grain mass is shown in Figure 1.

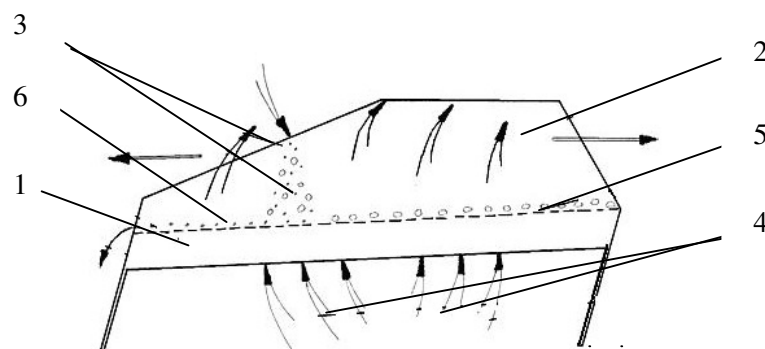

Fig. 1. Working diagram of the gravity separator connected to the suction system:

1 – working platform; 2 – suction room (hood); 3 – product supplying; 4 – aspirated air currents; 5 – heavy impurities particles; 6 – cleaned product

Figure 2 shows the functional diagram of a separation device of impurities combined from the mass of grain, consisting of a vibrating gravity separator 1 and a suction installation of light impurities (formed by suction fan 2, cyclone 3 for separation and collecting elements of impurities 4) [1; 2].

For the analysis of solutions to optimize the separation processes of impurities from the cereal seeds at these types of separators experimental determination of the influence of the functional parameters is necessary (flow rate of material supply, air flow of suction installation, direction of

propagation of oscillations of the vibrating plane of the separator, tilt and oscillations amplitude of the working surface) on the quality indices of the separation process (degree of separation of impurities, degree of loss of good seeds, index of technological effect).

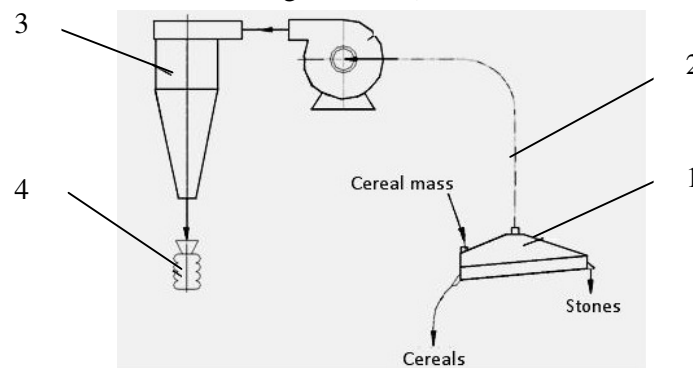

Fig. 2. **Functional scheme of the separation technical equipment used in the stand:**
1 – gravity separator; 2 – suction fan; 3 – cyclone; 4 – bags for light impurities and dust collection

Materials and methods

In the following the installation and the experimental determination research methodology is presented used to determine the qualitative indices of the separation process of impurities from grain seeds in the case of combined separation systems (relative to the specific mass and the aerodynamic properties of seeds). The installation consists of the gravity separator model SP-00 (realised at INMA Bucharest, Romania) connected to a suction installation with air composed of the suction fan and the gravimetric separator (cyclone).



Fig. 3. **General view of the installation used in experimental research:** 1 – elevator; 2 – gravity separator; 3 – intensive vacuum separator; 4 – fan, 5 – dedusting cyclone;
6 – control and signaling panel

The method of adjusting the imbalance force acting on the shafts 3 of the driving electric motors of the vibrators unbalanced masses is given in Figure 4 [1; 3]. Adjustments are achieved by mounting of the plates 1 and 2 in different relative positions, of semicircular shape, the size of centrifugal force developed for different coverage degrees of the plate surface being given in the graph at the bottom of the figure. The experimental measurements were made in different versions, summarized played in the scheme of the program in Figure 5. The material used at the experimental researches was wheat (as seeds). This material was first introduced in the intensive vacuum separator, being subjected to the operation of separation by size. For experimental measurements measurement devices were used and/or registration of the following sizes (parameters): masses of products and impurities in the separation process; inclination angle respect to the horizontal of the working surface of the separator (vibrating sieve); air flow rate of the suction installation by determining the velocity of air currents in the suction pipe; oscillation amplitude of the working surface; frequency of oscillation of the

motovibrators, by determining their rotation speed; power consumption of electro-vibrating system of the separator; humidity and temperature of the processed product.

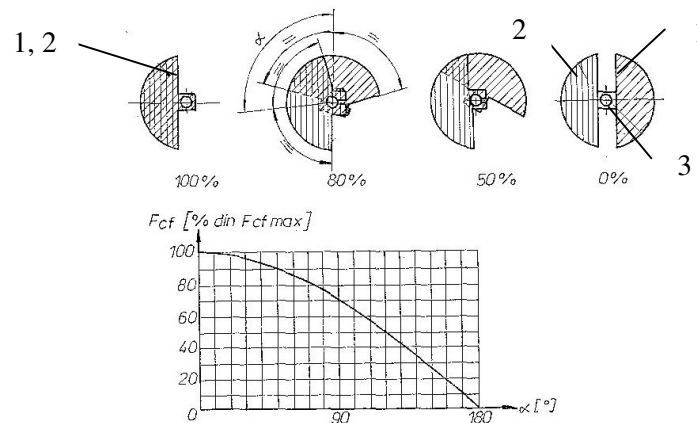

Fig. 4. Adjustment scheme of imbalance forces of the masses of centrifugal excitation control forces achieved by the motovibrators of the vibrating platform of separator:

1, 2 – control plates; 3 – drive shaft of the unbalanced masses

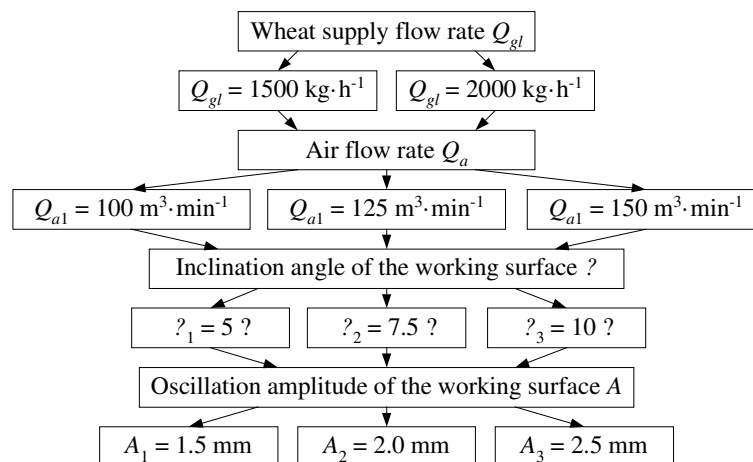

Fig. 5. Scheme of experimental test program

On entry and exit of wheat in the separator and at evacuation of impurities in the process of separation the following parameters were determined: humidity and hectoliter mass of wheat grains at the entrance in the separator; hectoliter mass of the resulting product in the process of separation; impurities content of wheat at the entry and exit from the separator.

The index of the technological effect E_{cs} represents the percentage of foreign bodies (impurities) eliminated from the mass of the processed product, determined with the relation [1]:

$$E_{cs} = [(C_{csi} - C_{cse}) / C_{csi}] \cdot 100, \% \tag{1}$$

where C_{csi} – content foreign bodies (impurities) at the entrance of material in the equipment, %;
 C_{cse} – content foreign bodies (impurities) at evacuation of material from the equipment, %.

The coefficient of loss of good seeds C_{ps} is calculated with the relation [1]:

$$C_{ps} = (m / M) \cdot 100, \% \tag{2}$$

where m – good seed mass which is found at the exit from the equipment in the quantity of total impurities eliminated; kg,
 M – good seed mass at the entry into the equipment, kg.

For the calculation of the technological effect the index E_{cs} was determined by weighing and calculation for the following sizes, reported to 1,000 kg of wheat processed by the separator: total quantity of impurities separated, kg; quantity of eliminated stones, kg; quantity of other impurities

eliminated (seeds of other nature including broken, non-eliminated light seeds, soil, etc.), kg; quantity of lost good seeds, kg.

Results and discussion

For an intuitive analysis of the influence of various constructive and functional parameters of the combined separation installation on the global technological index values E_{CS} graphics were drawn expressing the following technological dependency of the index values of the functional parameters (adjustment) of the separator: the supplying flow rate with product Q_g subjected to processing (wheat), the air flow rate Q_a of the suction installation, the angle of inclination respect to the horizontal working surface of the separator α_k and the oscillation amplitude A_k of the separator working surface.

In Figures 6 – 9, for illustration, some representative graphics are presented.

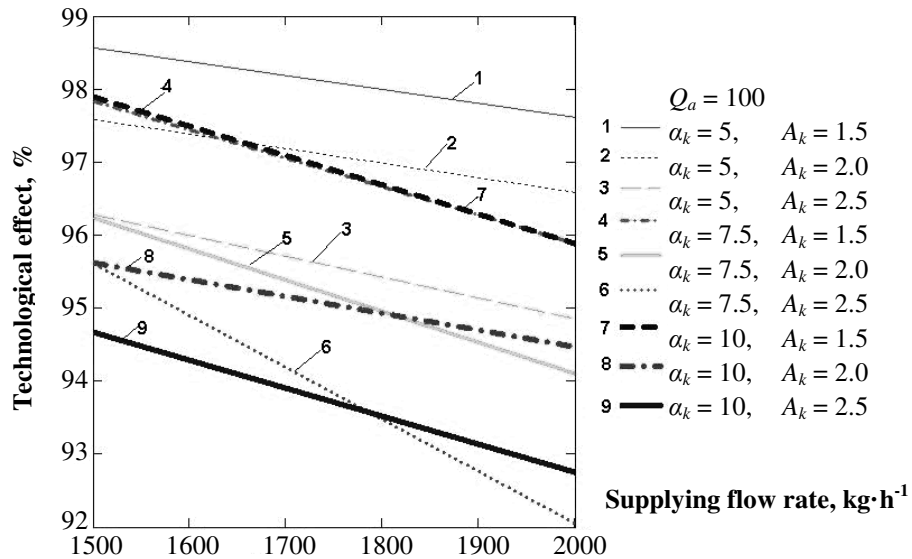

Fig. 6. Variation of the values of technological effect index E_{CS} depending on the supplying flow rate with material (wheat) Q_g at the suction installation flow rate of $Q_a = 100 \text{ m}^3 \cdot \text{min}^{-1}$, for the following adjustment parameters: inclination angle of the working (vibrating) surface $\alpha = 5; 7, 5; 10^\circ$ and working surface amplitude $A = 1.5; 2; 2.5 \text{ mm}$

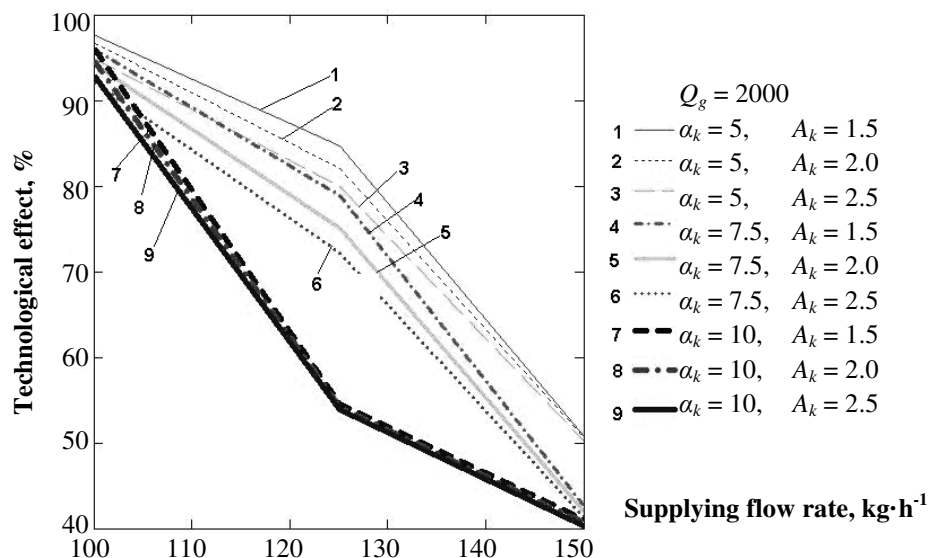

Fig. 7. Variation of the values of technological effect index E_{CS} depending on the air flow rate Q_a for the supplying flow rate with material (wheat) $Q_g = 2000 \text{ kg} \cdot \text{h}^{-1}$ for the following adjustment parameters: inclination angle of the working surface $\alpha = 5; 7, 5; 10^\circ$ and working (vibrating) surface amplitude $A = 1.5; 2; 2.5 \text{ mm}$

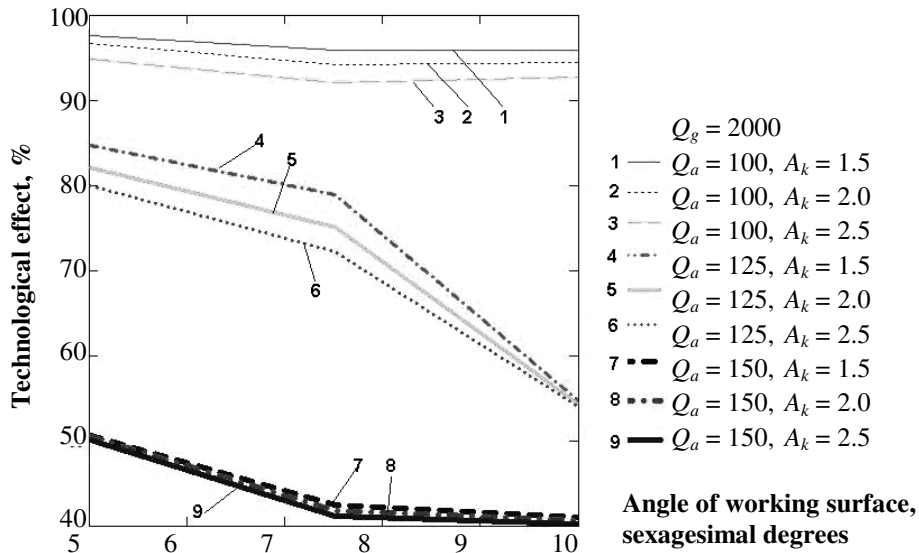

Fig. 8. Variation of the values of technological effect index E_{CS} depending on the angle of the working surface α at the supplying flow rate with material $Q_g = 2000 \text{ kg}\cdot\text{h}^{-1}$, for the following adjustment parameters: air flow rate $Q_a = 100; 125; 125 \text{ m}^3\cdot\text{min}^{-1}$ and working (vibrating) surface amplitude $A = 1.5; 2; 2.5 \text{ mm}$

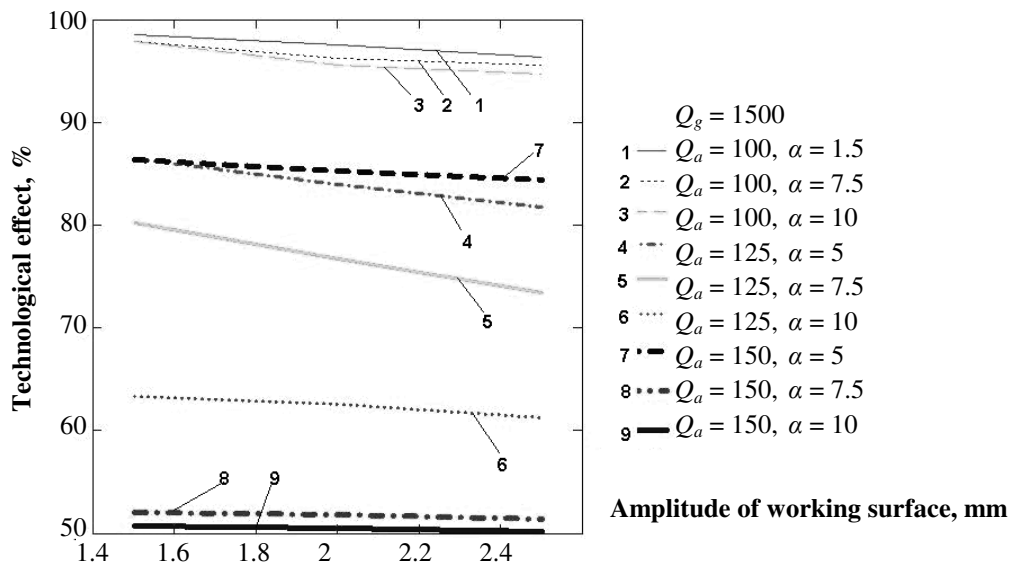

Fig. 9. Variation of the values of technological effect index depending on the working surface amplitude A for the supplying air flow with material $Q_g = 1500 \text{ kg}\cdot\text{h}^{-1}$, for the following adjustment parameters: air flow rate $Q_a = 100; 125; 125 \text{ m}^3\cdot\text{min}^{-1}$ and inclination angle of the working (vibrating) surface $\alpha = 5; 7.5; 10^\circ$

Conclusions

From the analysis of the data obtained by processing the experimental data revealed the following conclusions:

1. The suction current introduced into the gravity separator favours the stratification of particles uniform dimensionally but with different specific weights, their movement on the surface of the separator being possible even under the minimum impulses.
2. The values of the effect of the technological working index decrease with the increase of the supplying flow rate with material (wheat) of the separator, being more evident at low angles of inclination of the working surface (5°) and at lower flow rates of air suction.
3. The values of the working technological effect index decrease with increasing of the air flow rate of the suction installation in about 83 % of the cases tested; in 17 % of cases (where there are

intervals of increase and decrease with increasing of air flow rate) variation of this index is neither monotonically increasing nor decreasing monotonically. The analysis of the experimental data shows that 67 % of cases opt for convex variations technological effect relative to the air flow rate, the remaining reflecting a concave variation.

4. The technological working effect index values have a monotone decreasing variation with the angle of vibrant platform of the working surface: 77.8 % of the experimented cases show that the dependency of the technological effect to the working surface angle is nonlinear, the remaining showing a pronounced linearity closeness; 77.7 % from experiments highlight a convex curve of variation of the technological effect with the angle of the working surface, the remaining reflecting a concave variance.
5. The experimented working range in the researches on stand showed that the index of the technological working effect had an approximately linear variation with the oscillation amplitude of the working platform surface. Overall there was a decrease in the technological effect index with increasing of the amplitude of the working surface; although the amount of the separated heavy impurities is higher and an increase in the mass of good seeds eliminated in the mass of impurities is found.
6. The results obtained during the experimental researches reveal that the entire installation (stand) used consisting of the gravity separator and the suction installation comply with the requirements in terms of destination, of the purpose and functioning mode, of the possibilities for adjustment and servicing, working having a working capacity suitable to deposits from agricultural farms, cereal seed conditioning stations as well as technological flows from milling units.

References

1. Brăcăcescu C. Theoretical and experimental researches regarding the optimization of working processes of gravimetrical separators aimed at cereals impurities. PhD Thesis, Transilvania University of Braşov, 2011.
2. Krampe H. Transport, Umschlag, Lagerung. VEB Fachbuchverlag, Leipzig, 1990.
3. Popescu S., Țenu I., Brăcăcescu Carmen. Considerations on the utilization of electromagnetic drive systems in vibrating feeders for bulk solid agricultural and food materials. Proceedings of International Conference BIOATLAS 2008, vol.2, pp. 499 – 500.