

## OPTIMALIZATION OF SETTING PARAMETERS OF LASER CUTTING MACHINE

Natasa Naprstkova, Stanislav Dubsky

Jan Evangelista Purkyně University in Ústí nad Labem, Czech Republic

naprstkova@fvtn.ujep.cz

**Abstract.** The article is dealing with optimization of parameters for a specific laser cutting machine. The first part of the article contains a description of cutting material by laser ray according to Paret analysis. The second part of the article is focused on the analysis of the production costs for the most frequently produced parts in specific company and in frame of this there are described methods and procedures for optimization of work and the parameters on this machine. There is mentioned a description of the machine and its parameters as well as choosing of the materials and their thickness. Everything what is acceptable for optimization, recommendation of testing samples as well as controlling of technological limitation is required by the machine producer. The optimized parameters are evaluated in comparison with usually used materials and the parameters given by the machine producer. In the conclusion the results of the analysis and experiments are summarized, which were done for the specific machine.

**Keywords:** laser cutting, optimization, experiment.

### 1. Introduction

Today, modern technologies are increasingly available and increasingly widespread among small and medium-sized companies and the quality of the processed surface for various purposes is also important [1; 2]. In cooperation with industry in the region at FPTM for the company engaged in manufacturing metal furniture a task was settled, whether and how we can improve the efficiency of its production. Already at the beginning it seemed like a possibility to optimize the operating parameters of the laser cutting machine. However, to verify this assumption, it was necessary at first to do the analysis and on the base of it to do further steps. The article in the first part deals with the analysis of whether the laser cutting technology is the best savings for a company, and further deals with design and implementation of a series of experiments to optimize the parameters of the laser machine.

### 2. Analysis of the initial state

For processing of the required analysis it was necessary to first become familiar with the production possibilities of the company and with each workplace [3]. Furthermore, it was necessary to select the most-produced components and to quantify their production costs and then focus on the most expensive operation, where it is possible to bring the highest savings. The analysis of the manufactured parts was made (their frequency, method of manufacture, etc.), the production costs of their production were analyzed and selection based on the Pareto principle was made (Fig. 1).

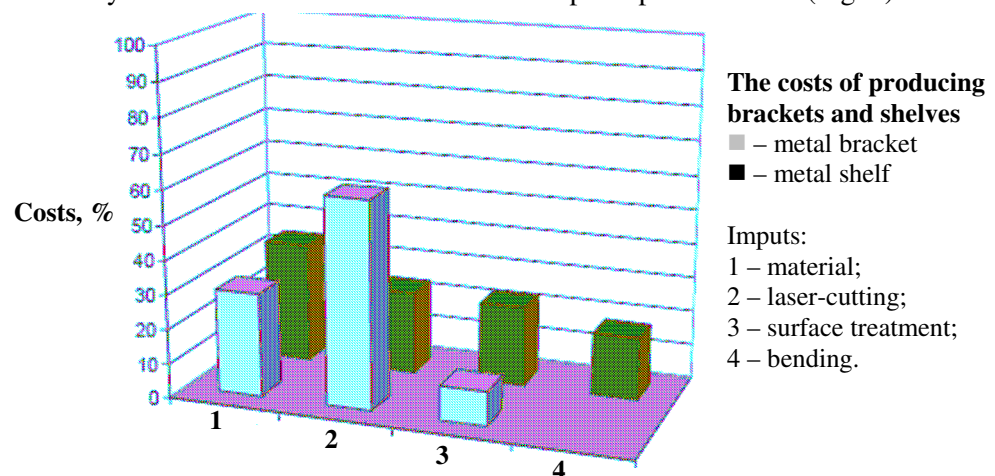

Fig. 1. Graph of the cost of the selected items production in the company

Figure 1 shows that the most expensive input in the production of the most manufactured parts is for cutting parts on the laser cutting machine and the input material. As a conclusion of Pareto analysis it was therefore concluded that it is necessary to look for savings in the laser cutting machine. By

optimizing the laser cutting parameters better use of the material can also be achieved, which was also addressed.

### 3. Laser cutting machine

After the analysis it was decided that the next optimization steps will involve the laser cutting machines, namely machines Platino 1530 [4]. It is a CO<sub>2</sub> gas laser with a wavelength of 10.6 micron and the cutting output of 3 kW. Repeatability of move to position is 0.03 mm. The linear axes are working with accuracy 0.001 mm. The machine uses flying optics (workpiece stays in place and moves the laser head). Its performance advantages in terms of the processed material are summarized in Table 1

Table 1

**Performance capabilities of the machine Platino 1530 [2]**

Material	Maximum theoretical thickness of the workpiece
steel grades according to ČSN-10,11,12	20 mm
stainless steel	12 mm
aluminium and its alloys	8 mm
plexiglas	12 mm
brass	6 mm

### 4. Optimizing of the performance parameters of the machine

After the analysis of the production costs of usually manufactured components, selecting the most suitable manufacturing operations to search for savings and mapping of the cutting parameters of the laser cutting machine has been selected. For optimisation of the performance parameters of the machine Platino the following steps and have been designed:

- determine the shape of the experimental sample for testing to match the machine parameters, specifying for which quality and thickness the parameters will be optimized, selection of a suitable stock for tests;
- technological preparation of production representative articles;
- design of experiment methodology;
- choice of the number of pieces needed to optimize the parameters;
- performance of the experiments according to the methodology and their evaluation.

#### 4.1 Selecting the shape of the experimental sample

Most parts are cut from sheet steel products quality 11 373 according with ČSN a thickness of 3 and 1 mm, and their size is 550x120 mm and 1000x500 mm. Such parts, however, are not well suited to carry out experiments (assumption was that during optimization of the parameters they will create a large number of nonconforming items and therefore it would be uneconomic to create defective pieces weighing 4 kg, which is the mass of material such as one particular real part). Therefore, for the testing of the parameters special samples, which contained elements that were suitable for testing the parameters and even dimensionally friendly with a few decagrams of weight, were proposed. The parameters such as the cutting speed, gas pressure and cutting performance, are equally well reflected in the large and small components. The size bridge between the parts, size and shape of the path laser beam to the cutting shape are then reflected in better results for small to medium sized products. At work they are most fired, there are only 4 holes Ø5 mm, for hanging during coating. But on the representative sample there were several holes of various diameters designed and created, which could be assigned to different lines cut (suitability test raids when cutting). It then created a small part with the three holes of different diameters. The sample was designed in two different versions. They differed from each other in diameters, since there is a connection between the material thickness and cutting lines for the given diameter.

When optimizing the parameters of materials of different thicknesses, it was necessary to choose three diameters, which would be possible to assign by the cut lines (they exist four). The product also had to have long straight edges (at the cutting the machine can accelerate at a high cutting speed) and

indented sections, where high cutting speed too negatively affects the quality of the cut. There were two experimental shapes of parts designed and created, part A, for the material thickness 1 – 3 mm, part B for the material thickness 4.5 to 6 mm (Fig. 2, 3). These shapes were created using AutoCAD and saved in DXF format for further processing due to the CAM.

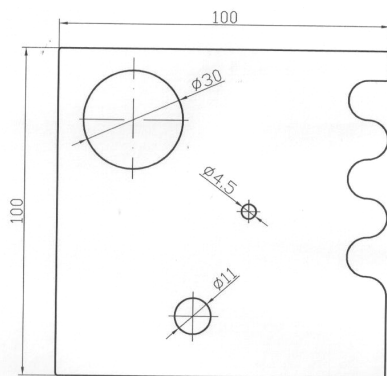

Fig. 2. Experimental part A

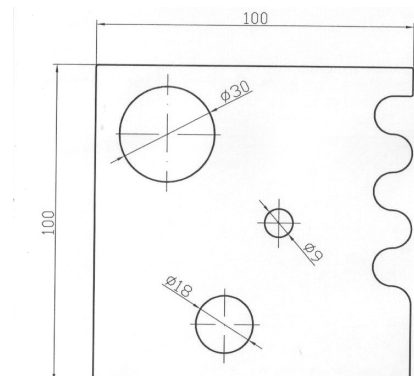

Fig. 3. Experimental part B

**4.2 Selection of the experimental sample thickness**

In the company there are products of different thicknesses and material grades processed. For economic and practical reasons it was not feasible to have optimized parameters for all materials and thicknesses, which allow the machine to cut. For production of certain materials there were no requirements from the customers over the last few years. Therefore, such materials have been excluded from the experiment and were selected to optimize the thickness of 1, 1.5, 2, 3, 4, 5 and 6mm. In Tab. 2 there is an overview of the percentage of various thicknesses of the material processed in the company.

Table 2

**The percentage composition expression of production in terms of material thickness**

Material thickness, mm	Proportion of machine time, %	Material thickness, mm	Proportion of machine time, %
0.8 – 1.0	29.0	6.0	7.0
1.5	15.0	8.0	0.6
2.0	18.0	10.0	0.2
3.0	16.0	12.0	0.1
4.0	9.0	15.0	0.1
5.0	5.0	–	–

**4.3 Selection of the material quality of the experimental work**

Similarly, the analysis of the machine using was made in terms of the quality of the processed material (Table 3). This table shows that 94 % of the machine running is used for processing of construction carbon steels. Therefore, the optimization did not address other materials.

Table 3

**The percentage composition expression of production in terms of material type**

Material type	Machine time, %
carbon steel	94.0
stainless steel	1.5
aluminium alloys	0.5
hot-dip galvanized steel	4.0

**4.4 Stock selection**

As already mentioned, mostly metal sheets are used in the laser cutting machine as a stock. It is usual that such a board is not used fully. And these residues can be used as the starting stock for optimization of the machine production parameters.

**4.5 Creation of the NC programs for optimization of machine parameters**

Furthermore, the CAM system Si-CAM was used for generating NC programs for experimental cutting parts. The programs had to be a total of 19 and they can be divided into two groups:

- programs for experiments with cutting speed, size and shape of size of approach the beam path (11 programs, resolution according to the thickness of the material, size and shape of approach the beam path);
- programs for the experiments with the size of bridges between the parts (for monitoring the impact of the size of the bridge between the parts on the quality of the cut – 8 programs, the distinction according to the thickness of the material, size and shape of the bridge).

**4.6 The choice of test pieces number**

As noted above, the optimization experiment was performed at a thickness of 1, 1.5, 2, 3, 4, 5 and 6mm. For each thickness of the material four tests were carried out to check the minimum size of the bridge. In each test 4 pieces of representative products were cut out (i.e., a total of 112 pieces). For each material thickness (7) it was necessary to implement 5 to 6 tests, which should optimize the size of approach the beam path. 38 units were created. At optimized cutting speed and cutting power beam 5 experiments were made on each thickness of the material (total 35 pieces). The overall design of pieces needed for the experiments was 188 pieces.

**4.7 Practical course of experiments**

The course of the experiments was carried out according to the procedures that have been identified with the developmental diagram (Fig. 4, 5, 6).

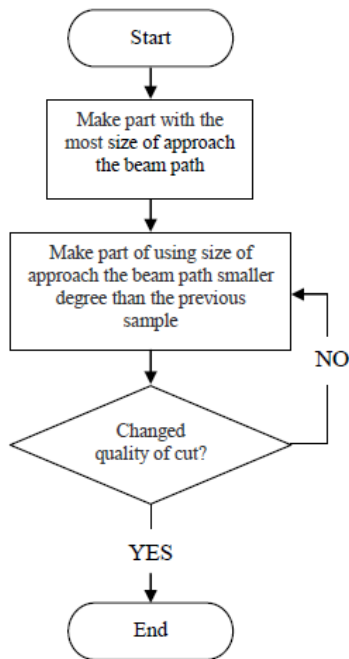

**Fig. 4. Flow diagram of experiment courses effects of approach the beam path shape on the size of cuts**

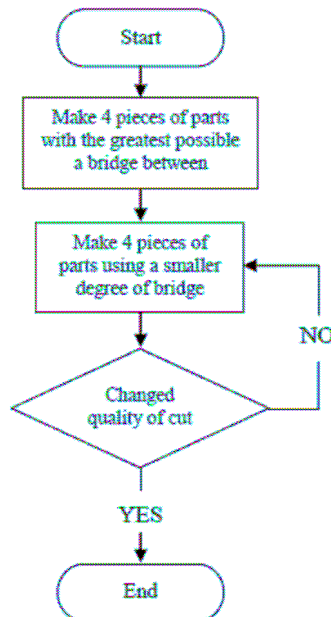

**Fig. 5. Flow diagram of experiment courses influences the size of bridges on the cut quality**

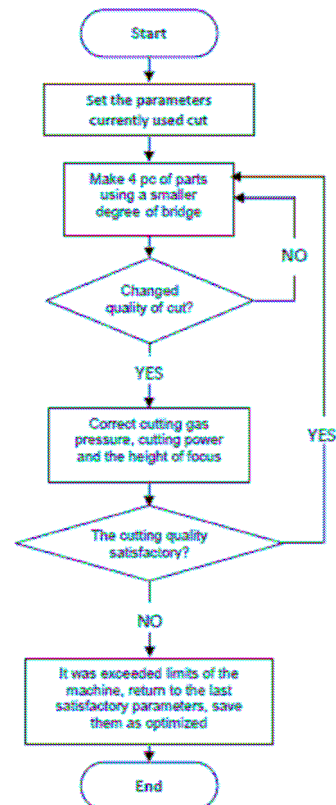

**Fig. 6. Flow diagram of experimet courses with increasing the cutting speed**

Figure 7 and 8 are examples of partial results of the experiments. Based on these experimental courses the results were evaluated according to the flowchart in Fig. 4, 5, 6.

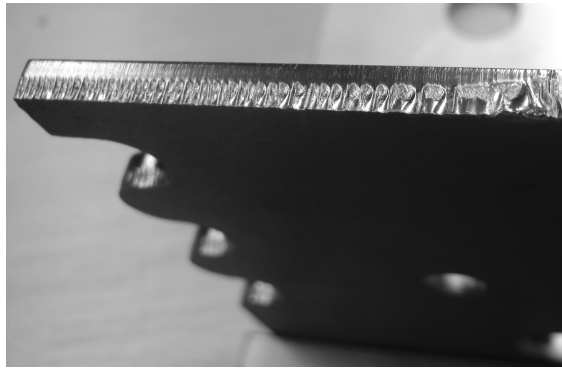

Fig. 7. Poor cut due to high cutting speeds, the sample thickness 6 mm construction steel

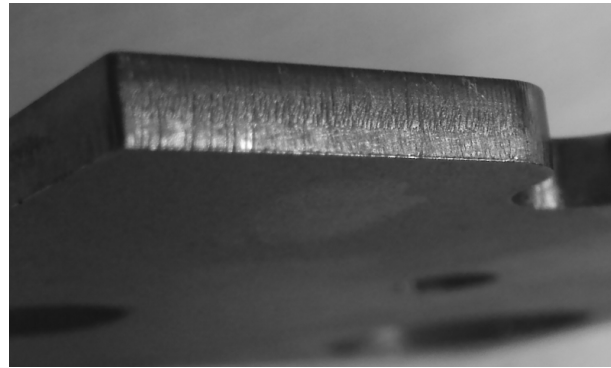

Fig. 8. Sample cut to the required quality construction steel thickness 6 mm

**4.8 Optimized cutting parameters and their comparison**

Based on the experiments it was found that the parameters recommended by the machine manufacturer do not allow to use the machine full performance. The results of these experiments are summarized in Table 4.

Table 4

**Using cutting speeds**

	Cutting speed, m·s <sup>-1</sup>						
	th. 1 mm	th.1.5 mm	th. 2 mm	th. 3 mm	th. 4 mm	th. 5 mm	th. 6 mm
<b>Manufacturer parameters</b>	6500	5500	4500	3300	3000	2100	1900
<b>Optimizing parameters</b>	8500	8000	6000	4400	3800	2700	2500

With the increase in the cutting speed there was, of course, an increase in the cutting performance (Table 5).

Table 5

**Using cutting power**

	Cutting power, W						
	th. 1mm	th.1.5 mm	th. 2mm	th.3mm	th. 4mm	th. 5mm	th. 6mm
<b>Manufacturer parameters</b>	1400	1500	1600	1500	1300	3000	3000
<b>Optimizing parameters</b>	2000	1600	1400	1400	1500	2300	2100

Likewise, there are some small changes in the pressure of the cutting gas. Their possible reflection in the total consumption of electricity and gas can be expected. However, the machine does not have facilities for accurate monitoring of consumption. To obtain convincing results would require long-term monitoring of consumption.

The issue of the size of the bridge solution contributes to the question of saving material. If the bridge is smaller, there is less waste. In Tab. 6 savings that result from the optimization of the size of the bridge are calculated.

Table 6

**Percentage of waste before and after optimization**

	<b>Current share of waste</b>	<b>New share of waste</b>	<b>Saving</b>
th. 1 mm	29.10 %	25.10 %	4 %
th. 1.5 mm	29.10 %	25.10 %	4 %
th. 2 mm	29.10 %	25.10 %	4 %
th. 3 mm	29.10 %	25.10 %	4 %
th. 4 mm	30.70 %	26.90 %	3.8 %
th. 5 mm	41.90 %	26.90 %	15 %
th. 6 mm	41.90 %	26.90 %	15 %

**5. Conclusions**

The solution to the given task was to find reserves in the use of laser cutting machines Platino. Series of experiments were performed in which the cutting parameters have been optimized for most grades of the processed materials and thicknesses.

Reserves have been identified both in setting the machine used in the manufacturing company as the manufacturer's recommendations. The company now has documentation on how to use the machine efficiently. Thanks to the optimization of the parameters it was possible to increase the cutting speed - see Table 4 and also by reducing the size of the bridges material savings were cut by about 4 to 15 % (depending on the type of the cut material, Tab. 6).

The authors are grateful for the support of experimental works by project GAČR101/09/0504.

**References**

1. Müller, M., Valášek, P. Interaction of steel surface treatment by means of abrasive cloth and adhesive bond strength, *Manufacturing technology*, 2010, vol. 10, p. 49 – 57.
2. Řasa, J. Laserové technologie a stroje s laserem (Laser technology and laser machines). *MMspektrum*. [online]. 2008/09 [25.11.2010]. Available at: <http://www.mmspektrum.com/clanek/lasery-lasrove-technologie-a-stroje-s-laserem>
3. Sábíl, J. Bakalářská práce - Zhodnocení efektivnosti nasazení laserového vypalovacího stroje (Bachelor Thesis - Evaluation of the effectiveness of the deployment of laser burning machines). UJEP, FVTM, 2009.
4. Platino 1530 – návod k obsluze stroje (Manual machines). Prima Industrie, Milano, Itálie, 2011.